



POWER-TECHNOLOGIE GmbH

Schulstraße 23
51491 Overath | Germany

P +49 (0) 2204 98 242-0 | F -22
info@pt-roads.com
www.pt-roads.com

ROADS EQUIPMENT

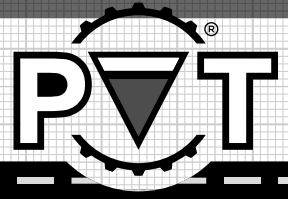

Tailor-Made Solutions:

COST-EFFECTIVE, PRODUCTIVE, FUNCTIONAL, ATTRACTIVE & ON TIME

The sum of these qualities is what makes our products a valuable proposition for you. Technical advantage means gaining a lead over the competition.

It can be crucial for increasing your profit margin. Benefit from our flexibility and our knowledge across sectors – or can you afford to pass on ideas?



WORKING 500 HOURS



THE BEST PLANING FOR NEW ROADS

NEWS



TWIST
TOOLHOLDER **W**
ADAPTER-UNIVERSAL
PT 11 - PT 20/22

+50 %

More service life on all round-shank bits due to best rotation using adapter technology



Less is more





We – Power Technology GmbH – develop and produce tools and machine components that are used for road building and other industries.

With our range of services and our philosophy FOR THE WORKER we approach forward-thinking clients who share our mission: Products that offer maximum workload reduction for the WORKER. For that we work with full commitment and push our efforts to the limit. We have great respect for all the workers who make our world a better place – with manual labour built on knowledge.

The new milling holder system from POWER-TECHNOLOGY GmbH Germany revolutionizes the future of road surface milling.

The current state of the art in the milling of road surfaces with round-shank bits, which are equipped with carbide tips and their corresponding holder systems, that show a high abrasion with a use of about 800 operating hours, is more than insufficient.

Due to the construction of the drum, which always has to be filled with milled material in order to be able to feed the truck via a conveyor, the tool holders are exposed to high wear with a working width of 1 meter – large milling machines with a 2-meter working width.

If the client wishes a clean and even 4 cm milling result, it is hard to realize using the current holder systems depending on the wear of the milling drum. Therefore, the milling result may not meet with the desired image and significant additional costs occur, because a later material correction is unavoidable.

Together with our valued competitors, we, POWER TECHNOLOGY GmbH, were looking for solutions in order to reduce the wear of the holder systems. Our director, Gerd Elfgen, called the mentioned problem area „a dark world that nobody can look into and in which even the desire of having the eyes of an owl would not help.“

For us it was clear that the previous holder systems, that only have one drill hole, would not solve the wear problem of the milling drums. The brilliant idea of a milling material deflector was born!

With our new holder construction, the milled material is rejected by the surface of the round-shank bit and at the same time by a circular recess the round-shank bit is constantly set to the required cutting angle.

Thus, the wear is immediately and demonstrably reduced. Not only that, but also the milling machine performance remains constant. With previous holder systems without alignment, the impact surface is deformed negatively by 7 degrees at about 800 operating hours.

The current state of affairs: The coefficients of friction in milling are getting stronger resulting in significant increase of fuel consumption.

The rotation of the round-shank bits is not as good anymore as the new holders, which leads to more downtime of the milling machines.

Thanks to our new holder generation, all of the above-mentioned negative influences and their consequences can be eliminated. We were able to reduce the wear of the holder surface by 50% for all test results, which is a sensational result! Moreover, it is possible at any time with the help of a replaceable, cost-effective cheap adapter to bring our holders to zero level without having to dismantle the basic holder.

We are convinced that our new holder system will help our clients in the future to work more consistent and cost effective in terms of road surface milling.

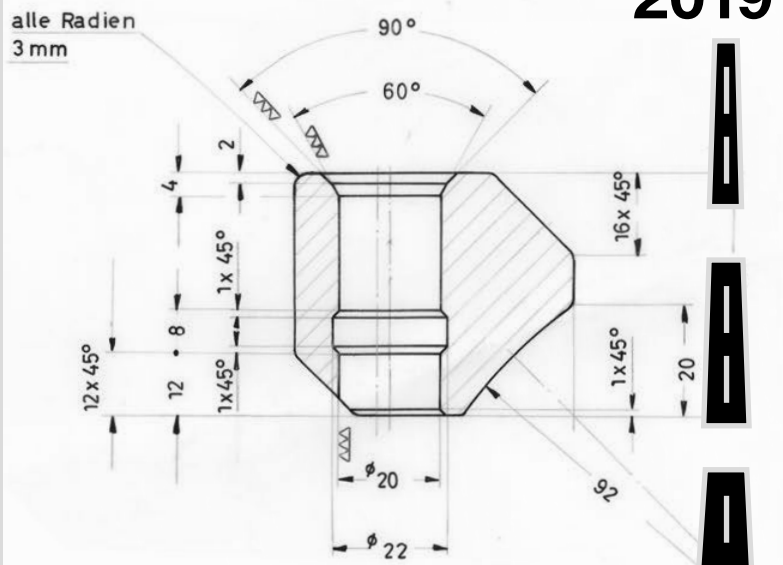
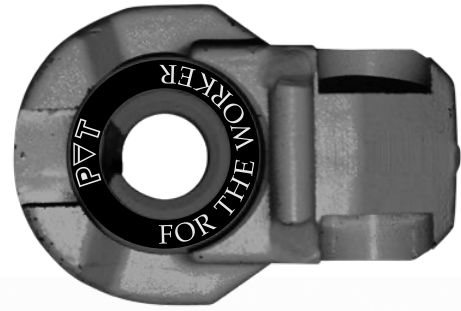

2019

Mehrverbrauch
inevitable!

aktuelle Frästiefe

aktuelle Schneidtiefe

Constant Cutting Angle

Rautiefe

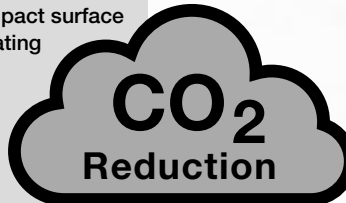
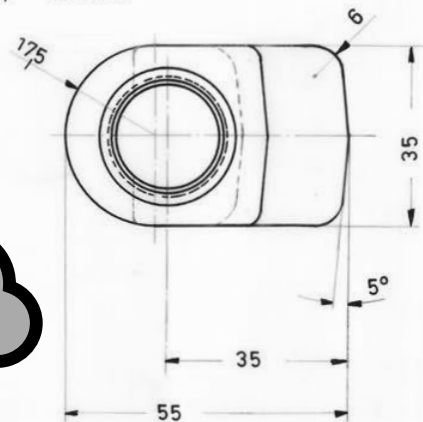

Maßstab 1:1		Mat.:
		1981
Bearb. Datum Name		ELFGEN - APEX
Gepr. 2.12.81		G M B H
Norm		
Rundschaft - Meißelbox		Blatt
Name		



POWER-TECHNOLOGIE GmbH

Schulstraße 23
51491 Overath | Germany

P +49 (0) 2204 98 242-0 | F -22
info@pt-roads.com
www.pt-roads.com

ROADS EQUIPMENT



**THE BEST TOOL SOLUTIONS
ARE OUR DRIVING FORCE**

Premium tools

- collaborative
- durable
- innovative
- high-quality

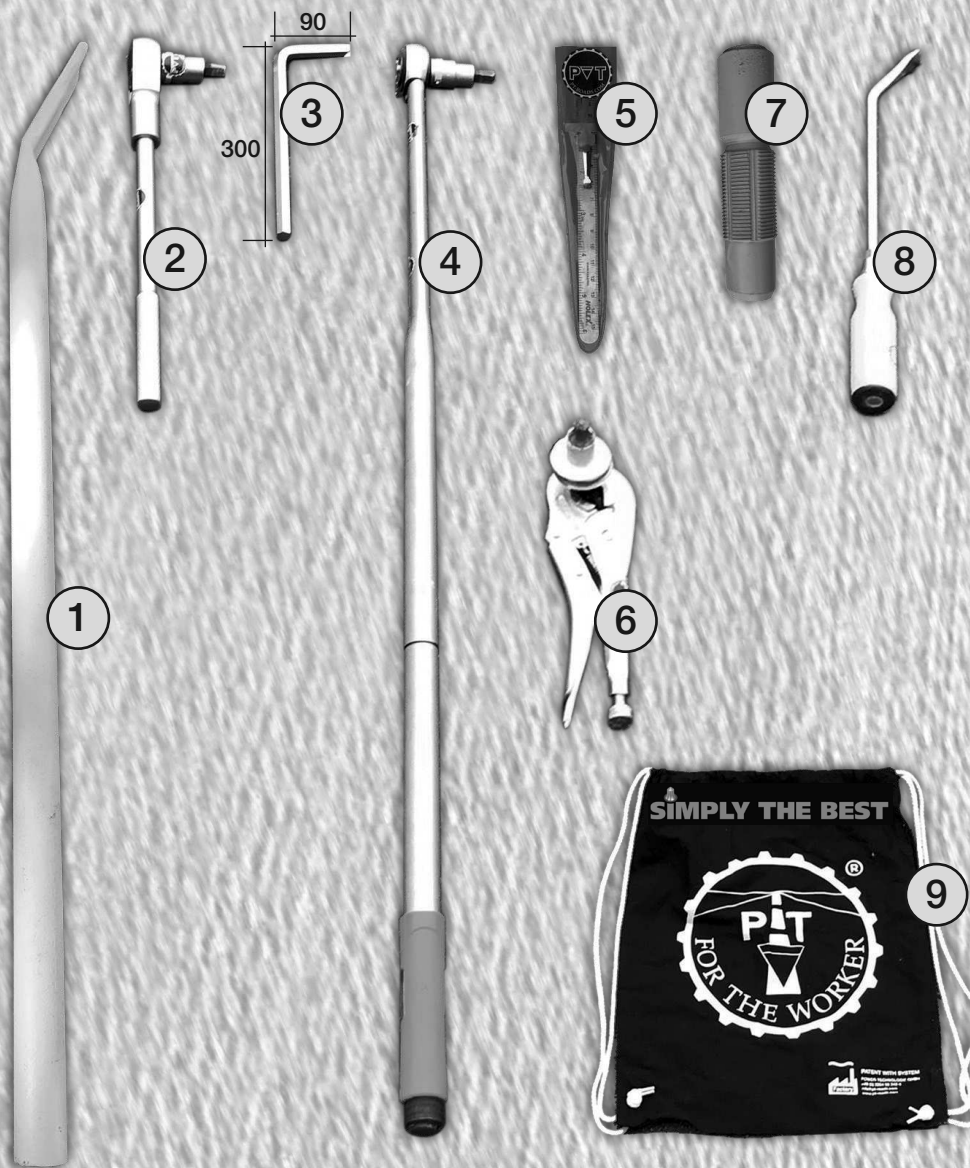

order number:	name
1	Combi tube 48.3x3.25mm galvanised extension tightening screw & lever aid
2	3/4 ratchet head with handle, with hexagon socket screwdriver 17mm hexagon
3	Hexagonal offset screwdriver 17 special dimensions 300 x 90 mm
4	3/4 torque wrench with setting scale 200-1000 Nm with hexagon socket screwdriver 17 hexagon
5	Steel rule with sliding clip stainless 150 mm measuring length Universally usable
6	Universal grip pliers with double prism (special version with 20 mm bore for round-framed chisels)
7	Special thread former for clamp-screws M30x2 mm with 17 hexagon hardness: Rockwell A 83 HRC
8	Universal lever for dismantling with wooden handle beech wood through blade for striking
9	PT cotton pouch PT „FOR THE WORKER“ for utensils